

T365 – Tub 365ml PP

Issue Level D: 28/09/2022

Page 1 of 2

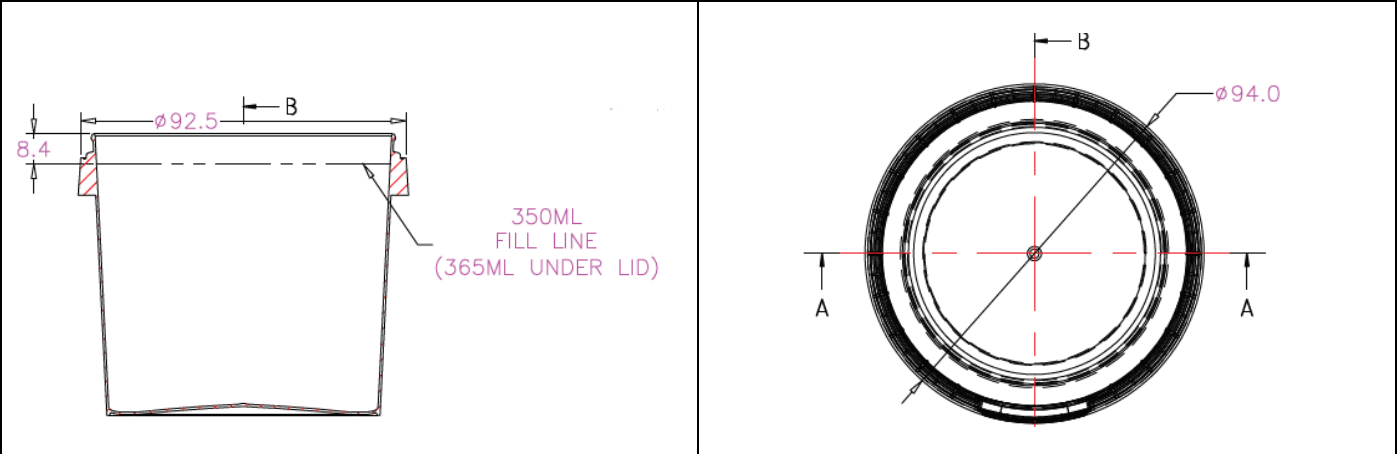

Dimensions	Refer drawing above. All dimensions are measured in mm. Tolerance for all measurements is +/- 0.25mm		
Shape	Round Tapered		
Tamper Evidence	Tamper evidence break-out tab (designed to be removed from container)		
Lid Options	Lid L94	Closure Plug Fit	Seal Medium Integrity
Volume	Volume underlid Recommended Fill	365ml 350ml	
Weight	Tub without Lid Tub with Lid	18.8gm 23.99gm	
Packaging	Units per carton Carton Dimensions Carton Weight Carton Liner Cartons per Pallet Units per Pallet Pallet Dimension inc Pallet Pallet Cube inc Pallet	432 L 580 x W 390 x H 415mm 9.6kgs Polyethylene 30 12,960 1200 x 1200 x 2240mm 3.23m ³	
Raw Material	Polypropylene (PP) Products are manufactured from food grade plastic polymers that comply with U.S. Food & Drug Admin (FDA) Regulations 21 CFR part 177.1520 for olefin polymers, EU Directive EU 10/2011 or AS 2070 -1999		
Environmental	The material used to manufacture this product is recyclable ♻		
Colours	Natural. Other colours available on request.		
Labels	In mould labelling (IML) optional		
Quality	Techno Plas is ISO 9001:2015 certified		
Food Safety	Techno Plas is HACCP certified		
Performance	<p>Hot Filling Suitable – Temperature to be determined by the user.</p> <p>Freezing Suitable – Temperature to be determined by the user.</p> <p>Re-heating This product can be microwaved.</p> <p>Washing This product is dishwasher safe</p> <p>Shelf Life Provided the product is stored, handled appropriately and remain in original condition with no damage to the packaging or product, the expiry is 5 years from date of manufacture. <i>The information provided is a guide only; internal trials should be performed to determine suitability of this product for the intended use.</i></p>		

T365 – Tub 365ml PP

Issue Level D: 28/09/2022

Page 2 of 2